

DIGITAL THREAD AND LOGISTICS: RUGBY IN A BROOKS BROTHERS SUIT?

LEON MCGINNIS
PROFESSOR EMERITUS
GEORGIA INSTITUTE OF TECHNOLOGY



NIST MBE Summit 2017



- The Summit's purpose is to identify challenges, research, implementation issues, and lessons learned in manufacturing and quality assurance *where a digital three-dimensional (3D) model of the product serves as the authoritative information source for all activities in the product's lifecycle.*

<https://www.nist.gov/news-events/events/2017/04/model-based-enterprise-summit-2017>



How far we have come!



The Context

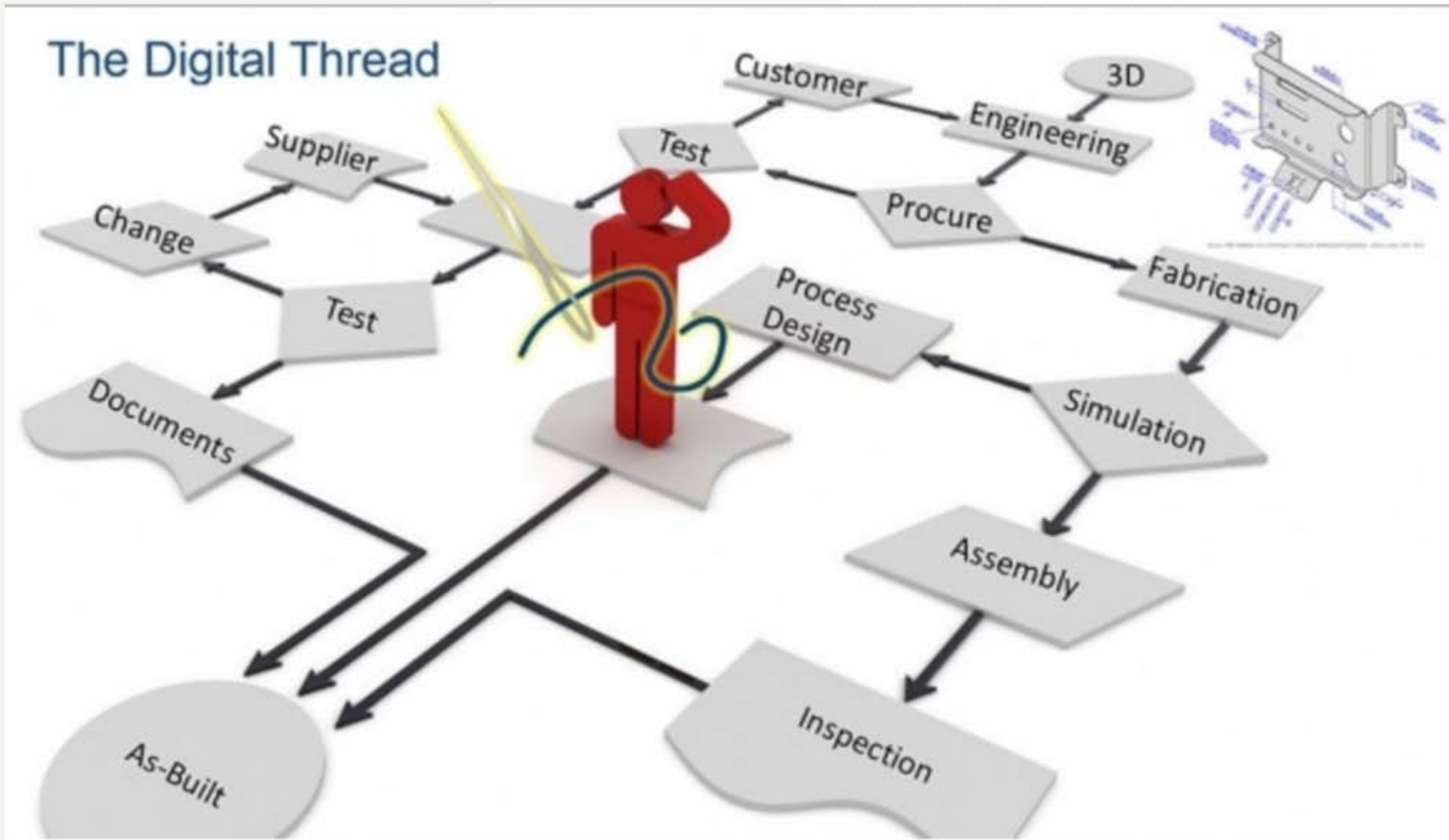

<http://www.industryweek.com/systems-integration/demystifying-digital-thread-and-digital-twin-concepts?page=2>

It's all about **LEVERAGE**

A Continuum of Authoritative Digital Surrogate Representations Leveraged Over the Entire Life Cycle

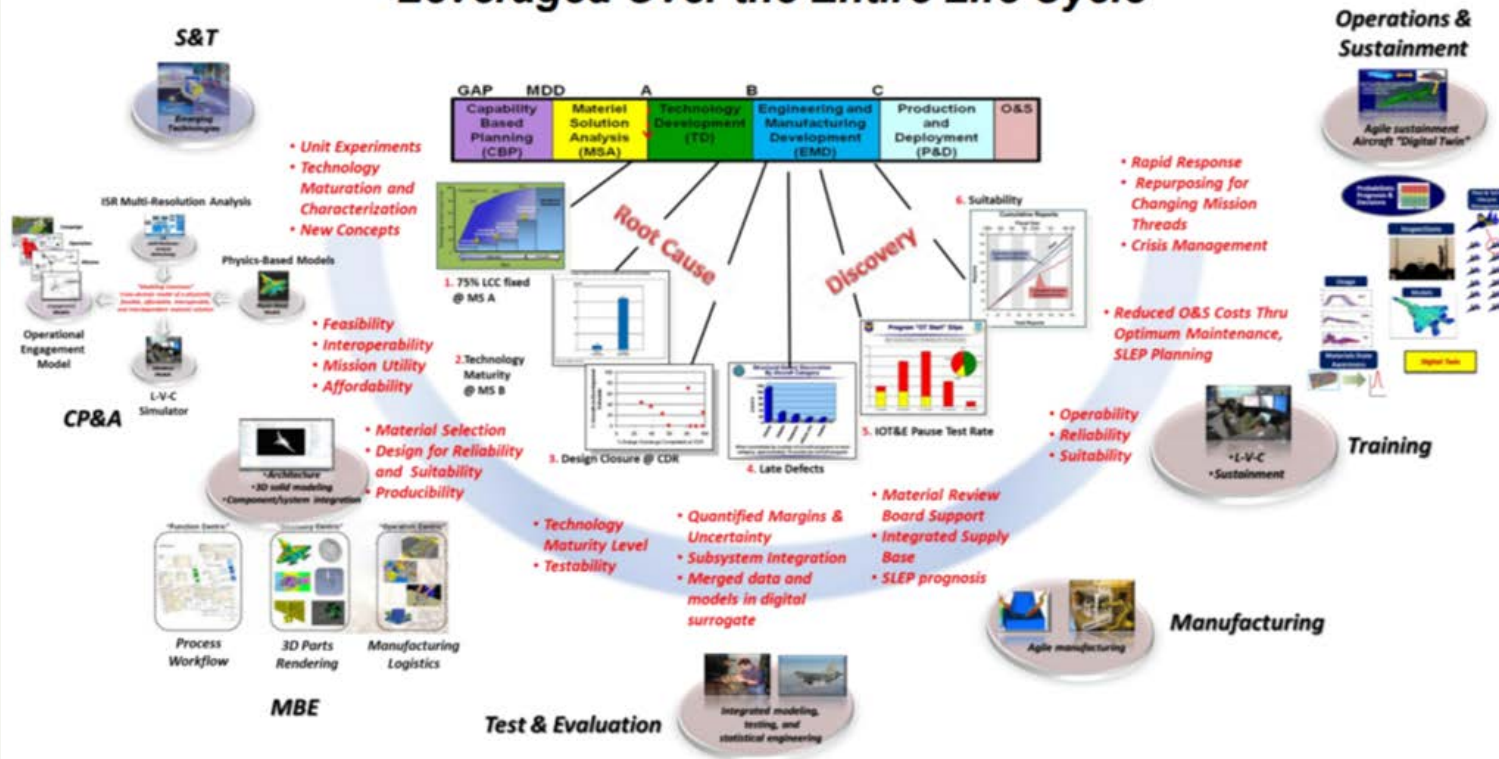

Dr. Ed Kraft, Technical Adviser, Arnold Engineering Development Center
https://www.nist.gov/sites/default/files/documents/el/msid/1Kraft_DigitalThread.pdf

What makes all this possible?

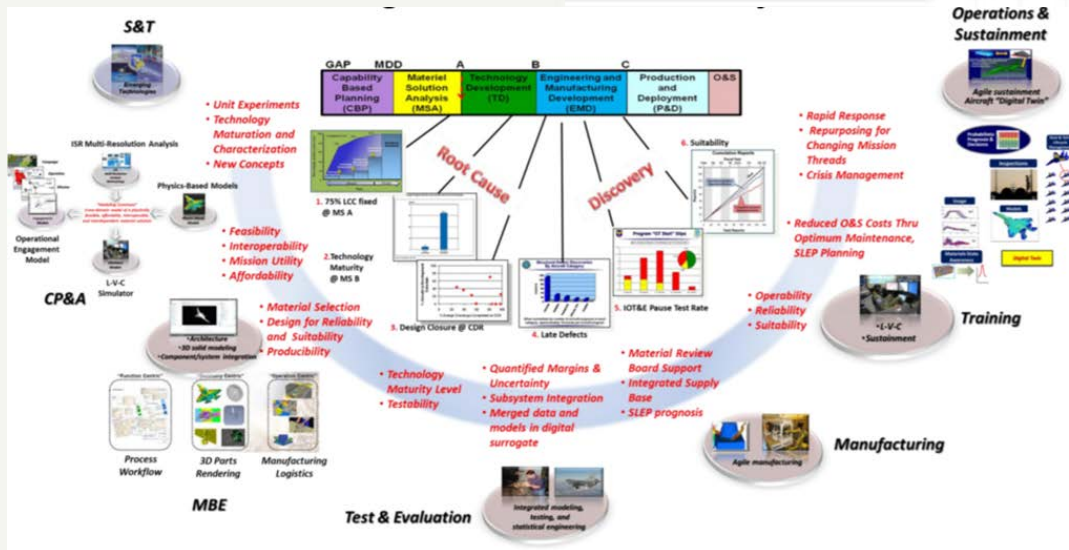

A **reference model** in systems, enterprise, and software engineering is an abstract framework or domain-specific ontology consisting of an interlinked set of clearly defined concepts produced by an expert or body of experts in order to encourage clear communication. [Reference model - Wikipedia](https://en.wikipedia.org/wiki/Reference_model)
https://en.wikipedia.org/wiki/Reference_model

No “universal” reference model, but at least in each domain of interest, an agreement on the semantics; necessary for a robust marketplace of solutions.

Are we missing an opportunity?

A Continuum of Authoritative Digital Surrogate Representations Leveraged Over the Entire Life Cycle

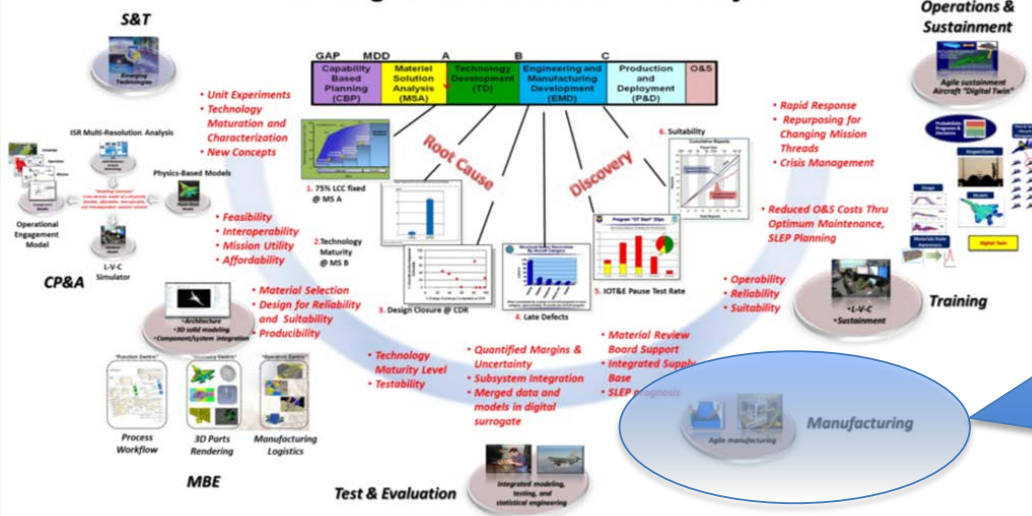

There is a LOT more going on than the connection between the product model and the individual manufacturing processes.

“Logistics” inside the factory

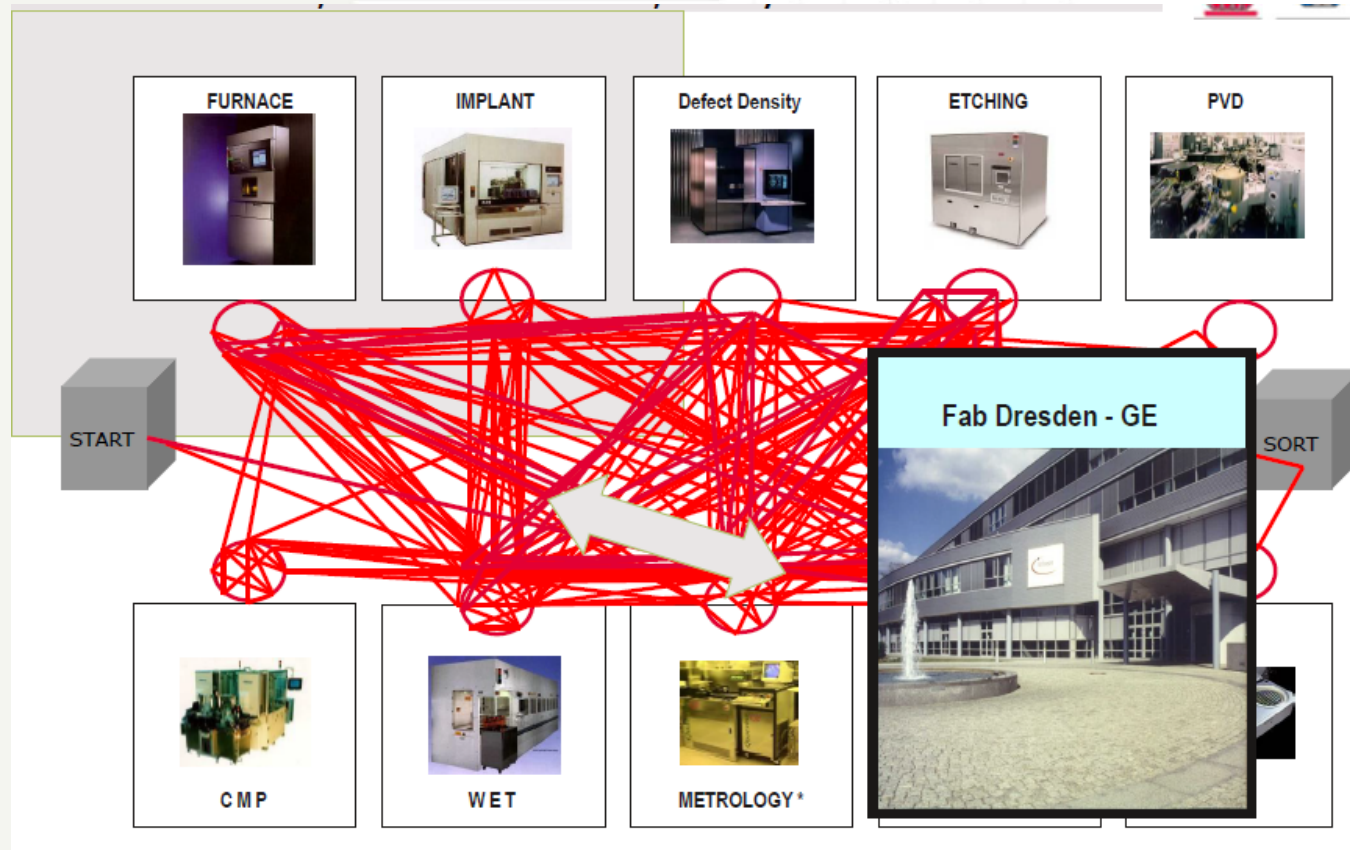

Hans Ehm, “Industry Overview,” Dagstuhl Seminar, Feb 8, 2016.

Global logistics

Each new supply chain was a step to win customers via capa increase – example from the qualification flexible mobile phone business

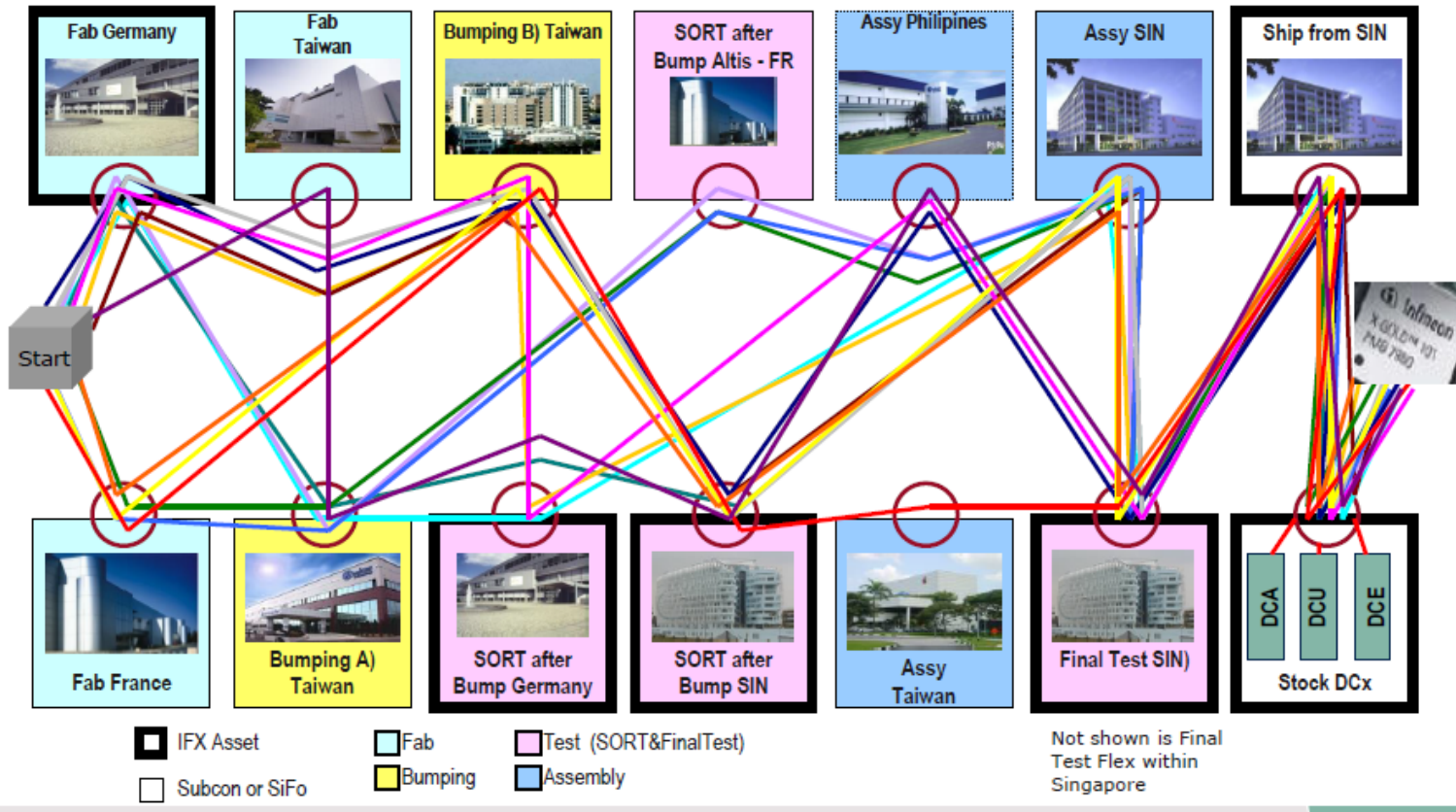

Hans Ehm, "Industry Overview," Dagstuhl Seminar, Feb 8, 2016.

Logistics network issues

Network Visualizations: % Sales + Financial Health

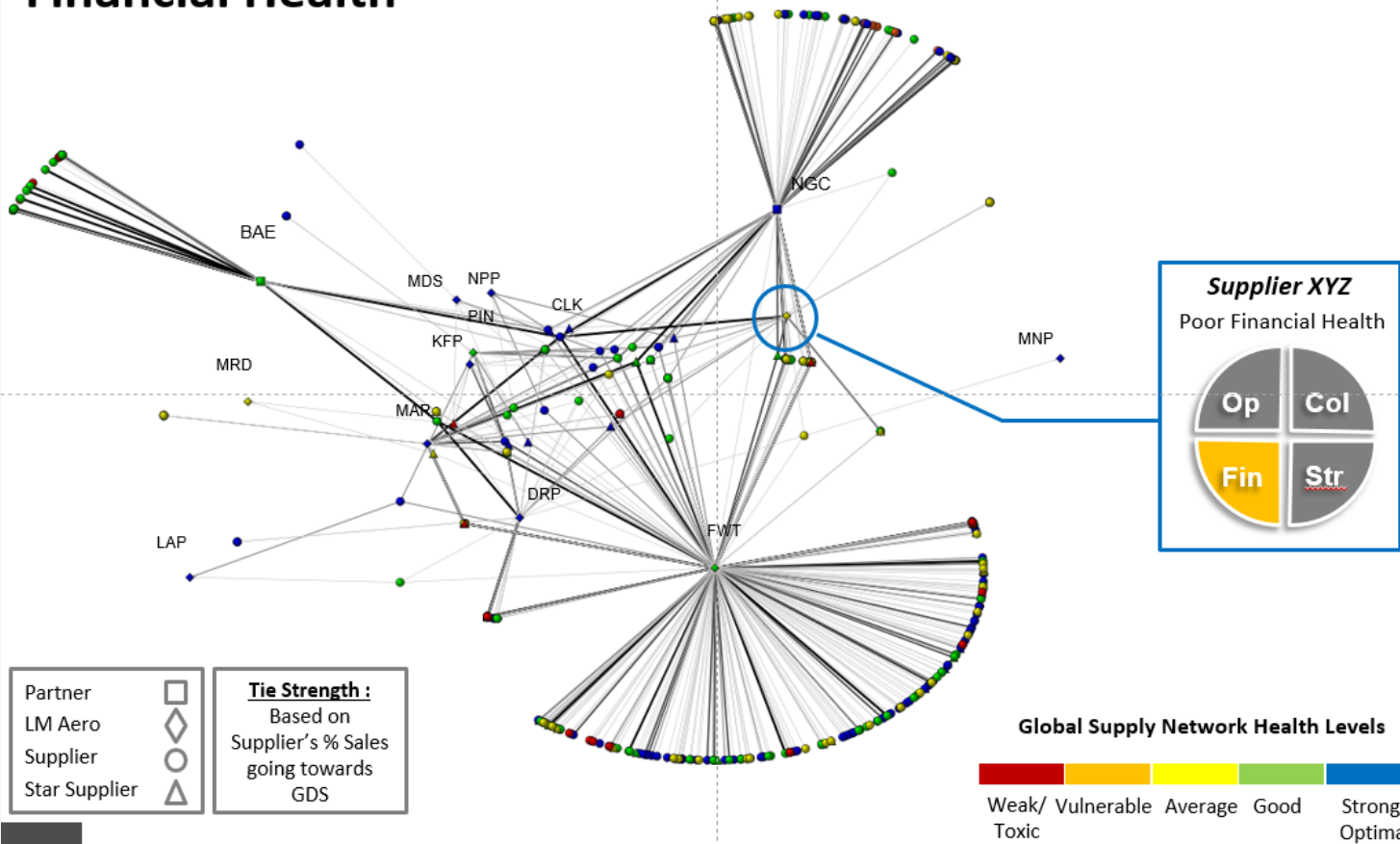



Logistics Decision Making

WHAT PRODUCTION TECHNOLOGIES?

How is production allocated?

Who are the suppliers?

Where are they located?

Contingencies?

What about inventories?

Where are our factories?

What do our factories produce?

How do we transport?

Planning

Accept a job?

Which resources to assign?

How to sequence tasks?

When to change resources?

Where does job go next?

**Operations
Management**

Behavior

- G00 - Positioning at rapid speed; Mill and Lathe
- G01 - Linear interpolation (machining a straight line); Mill and Lathe
- G02 - Circular interpolati
- G03 - Circular interpolati
- G04 - Mill and Lathe, Dw
- G09 - Mill and Lathe, Exa
- G10 - Setting offsets in th
- M00 - Program stop; Mill and Lathe
- M01 - Optional program stop; Lathe and Mill
- M02 - Program end; Lathe and Mill
- M03 - Spindle on clockwise; Lathe and Mill
- M04 - Spindle on counterclockwise; Lathe and Mill
- M05 - Spindle off; Lathe and Mill
- M06 - Toolchange; Mill



What About...?



Digital Factory

Industry 4.0

IIoT

CPS

Brilliant Factory

What About...?





What Is The Problem?

WHAT PRODUCTION TECHNOLOGIES?
How is production allocated?

Who are the suppliers?
Where are they located?

Contingencies?
What about inventories?

Where are our factories?
What do our factories produce?
How do we transport?

Accept a job?
Which resources to assign?
How to sequence tasks?

When to change resources?
Where does job go next?



Digital Factory

Industry 4.0

IIoT

CPS

Brilliant Factory



In this domain, our “wetware” does not have the same level of technical support for decision making that is common in the systems design domain.

The Elegant Design Intention Meets the Rough and Tumble of the Global Production System



Why Should You Care?

The quality of all this (logistics-related) decision-making has a huge impact on cycle time, cost, reliability, and risk.

You can't settle for historical performance!

What Can Be Done?

Leverage the lessons learned from MBE, MBSE, CAx, CAxI/F, etc to improve production system decision making!

Integrate production system knowledge into the system design process! DFL...



First, Identify The Domain

- Manufacturing systems are systems:
 - through which materials (**product**, tasks) flow
 - and are transformed by **processes** (make, move, store, measure)
 - executed using **resources** (people, equipment, inventory)
 - organized in some way (**facility** or network)
- Product/Process/Resource/Facility
- **Discrete Event Logistics Systems, or DELS**

**WHAT DO WE NEED TO
SUPPORT DELS PLANNING AND
OPERATIONS MANAGEMENT
DECISIONS?**



Basic Framework from CAx

Tools for capturing system models

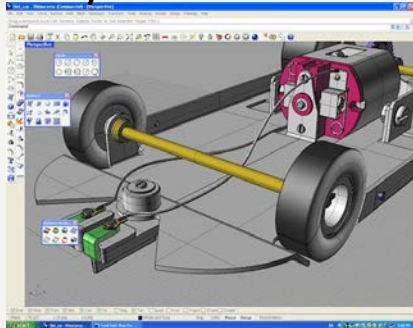

↑ conforms

Standard analyses for answering common questions

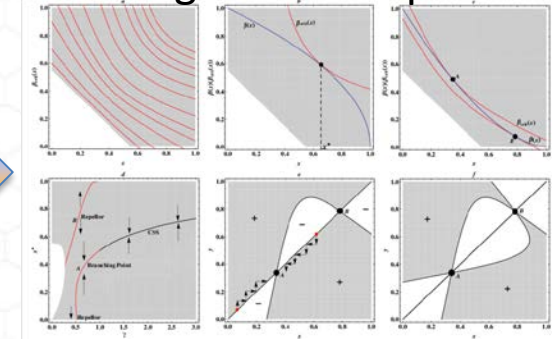

↑ conforms

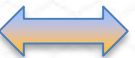
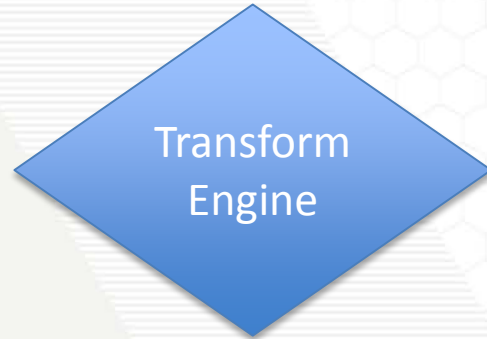
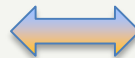
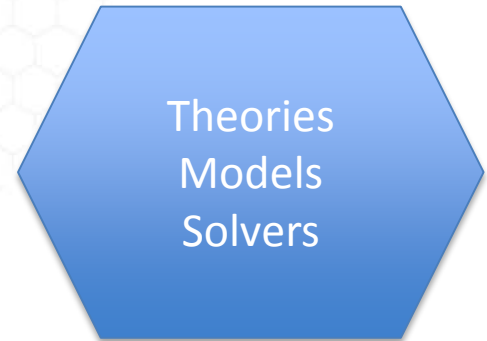
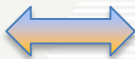
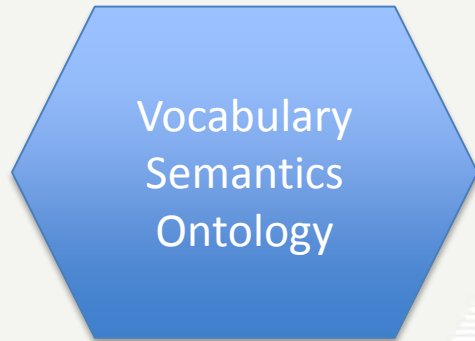



What Is Available Today For DELS?

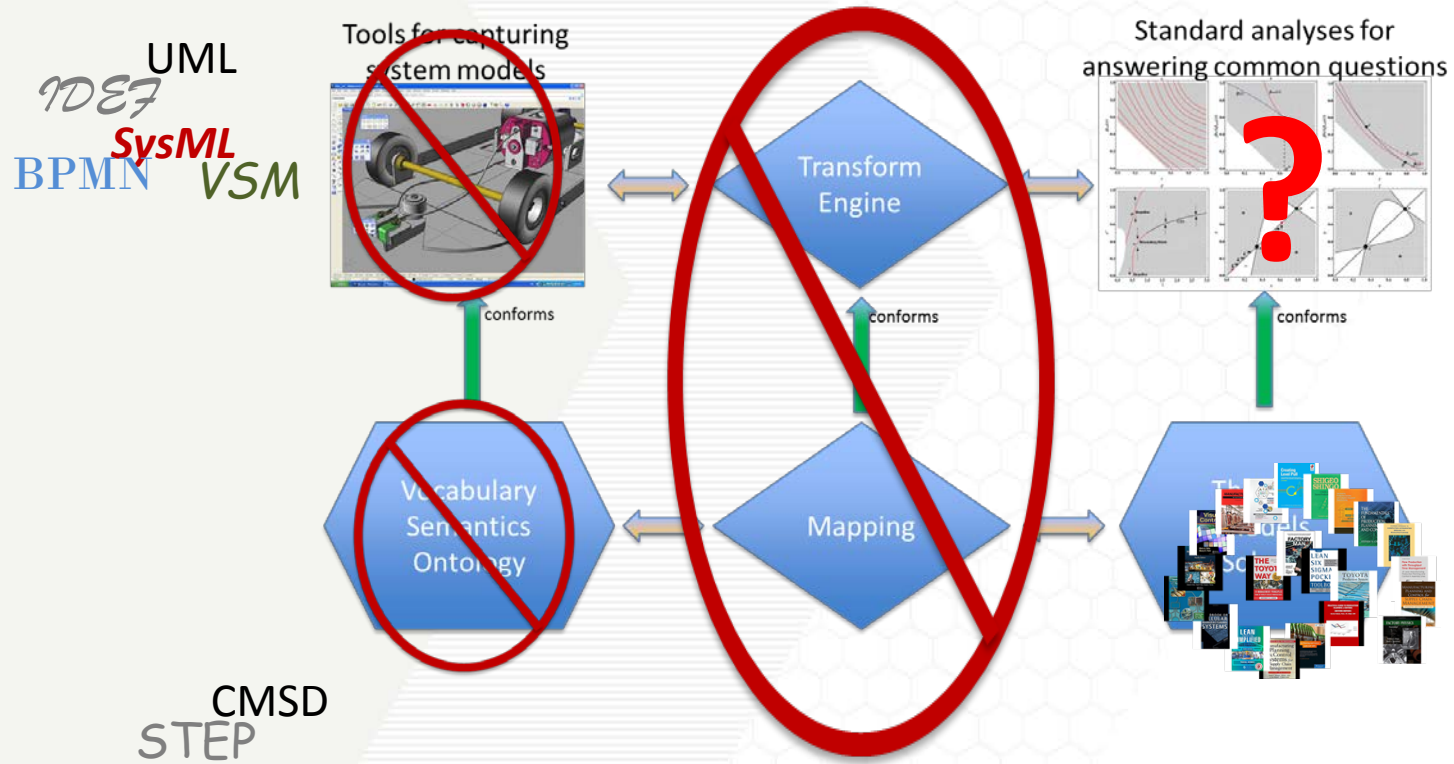



What We Do Have

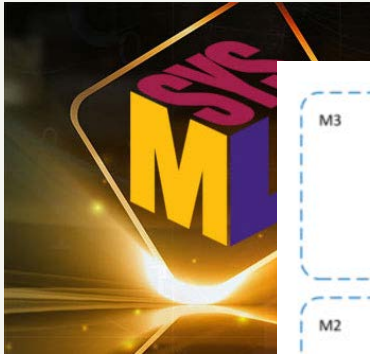

www.omgsysm

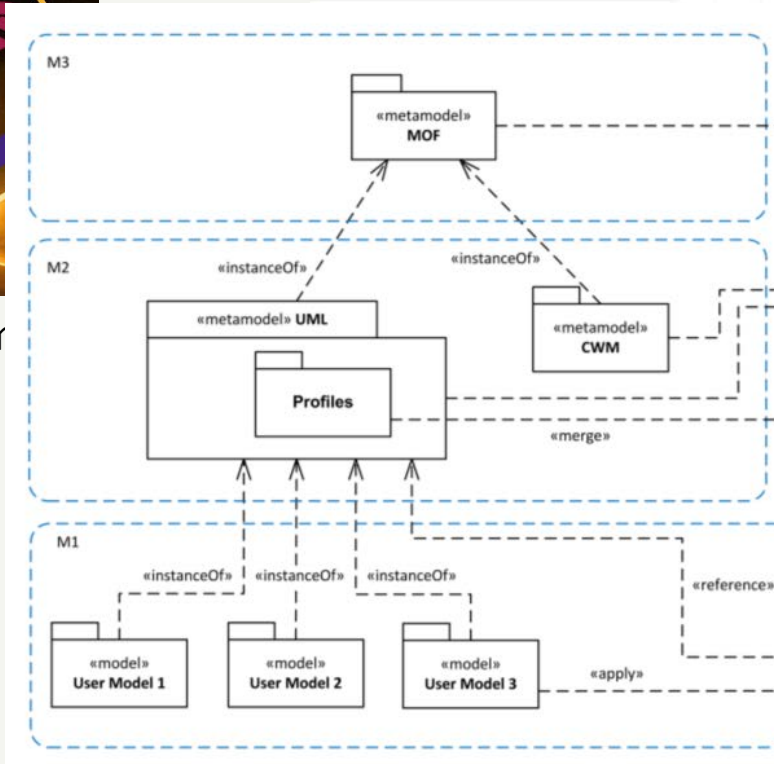

PSL
SCOR OAGIS
CMSD
OASIS

Industrial Partnerships!

<http://www.uml-diagrams.org/uml-meta-models.html>



One Example From Keck VFL

- Fast, cheap, good analysis models
- Layered abstraction
- Transformation technology
- Decision support

A Use case: SC design

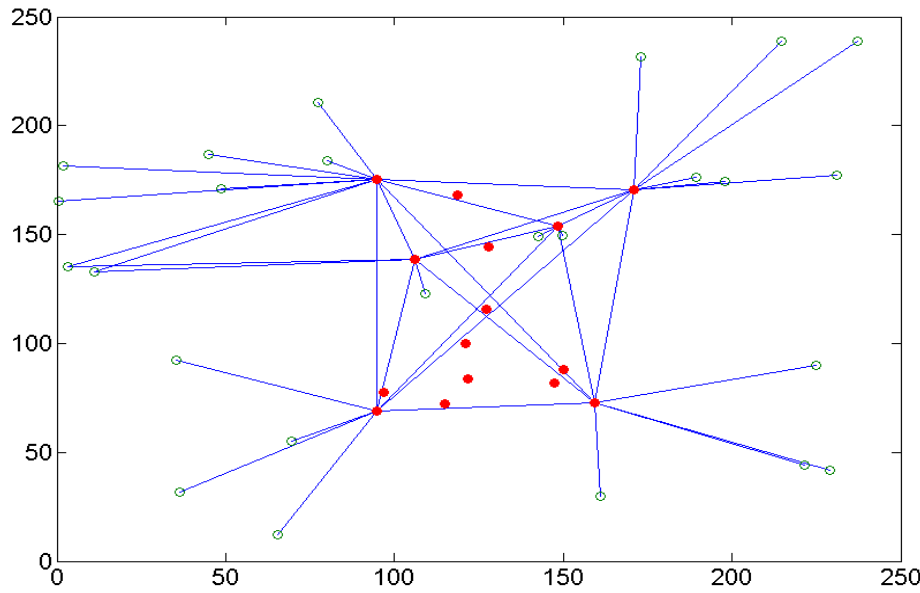

- Many locations where loads originate or terminate
- Many possibilities for distribution center locations
- Many possibilities for fleet configuration at each DC
- Want to guarantee delivery lead time
- Uncertain pickup/drop rates at each customer

- If you care about both cost and service level, how many DCs should you have, where should they be, how should you configure each DC's vehicle fleet, and how should you dispatch vehicles?
- Not just an optimization problem, because of control and uncertainty.
- Not just a simulation problem, because of facility and fleet configuration decisions.

Network meta model

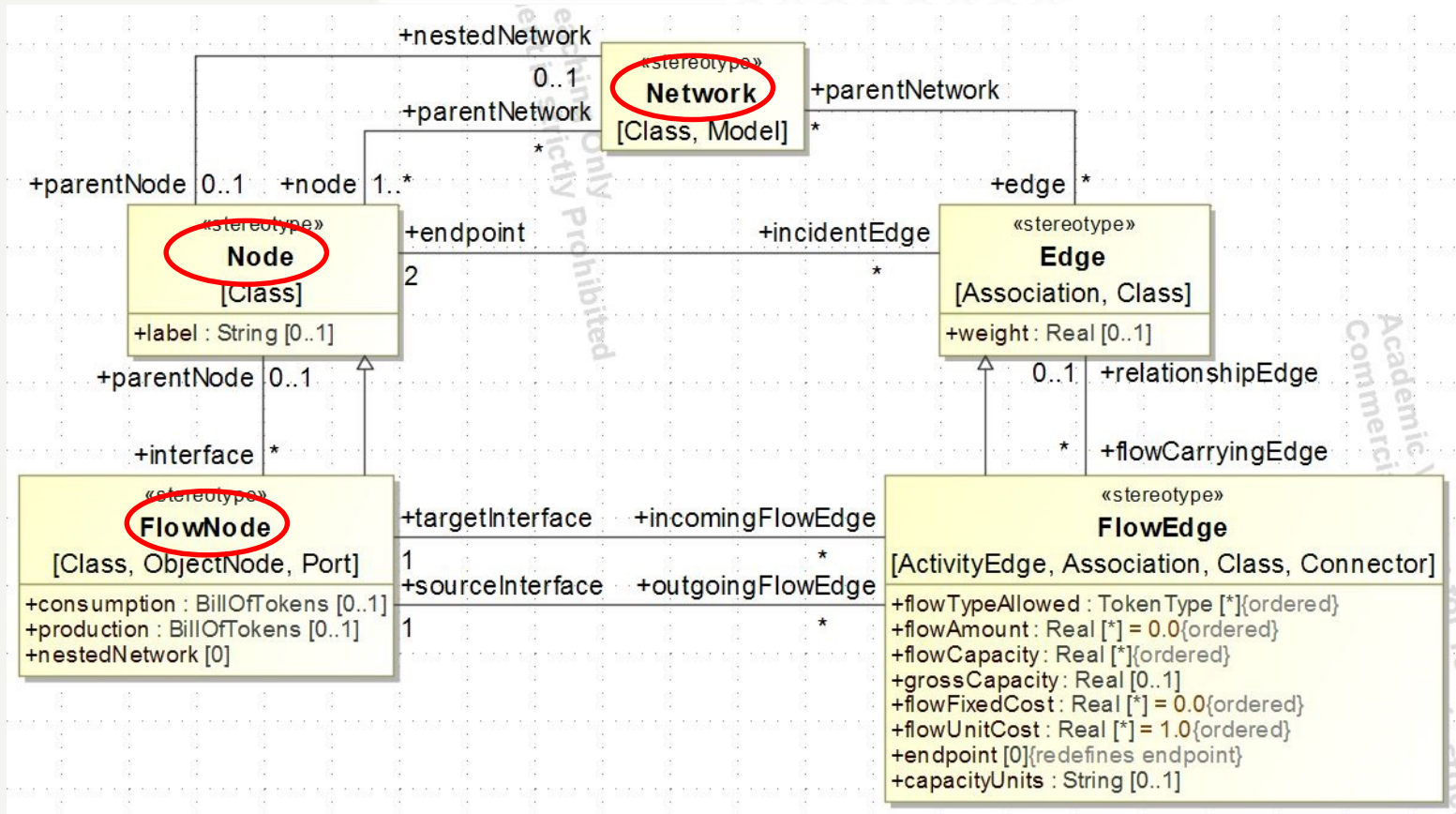

An example of a “meta-model” defining the semantics for creating an instance model of a particular (abstract) network.

SC Meta model elements

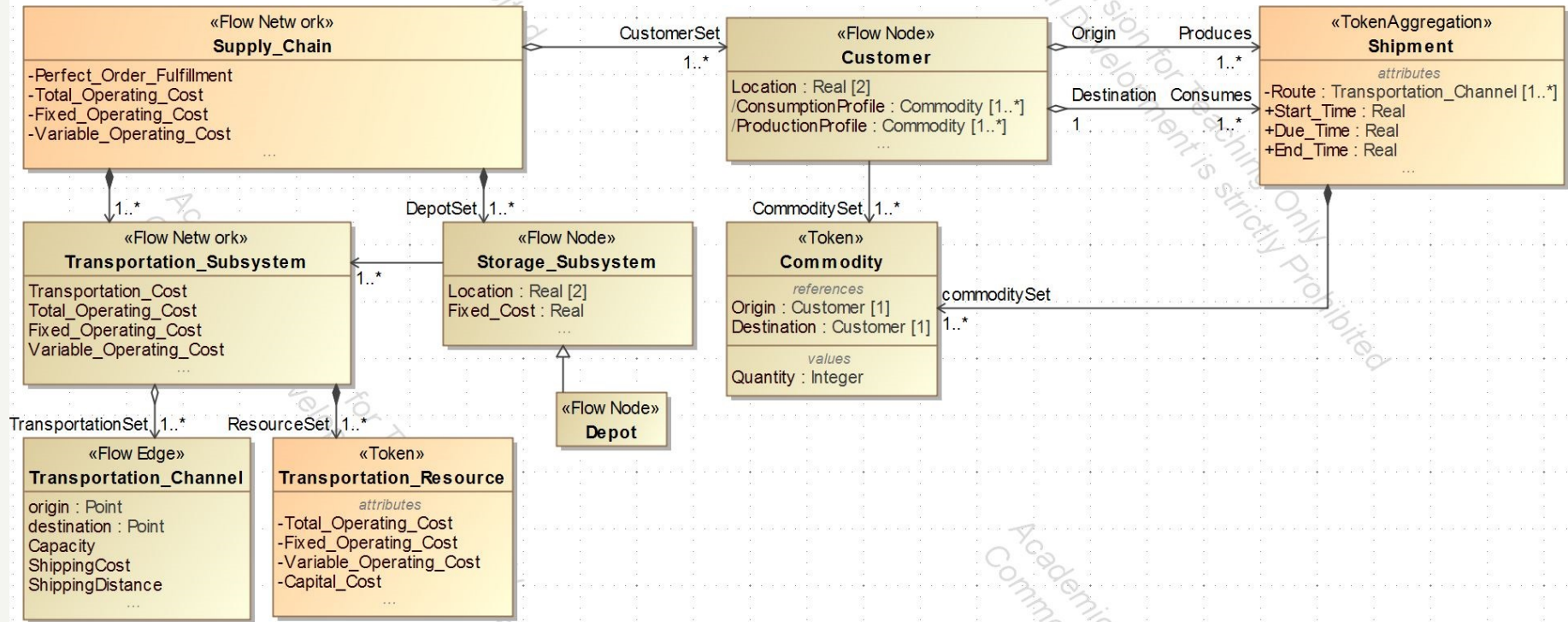

Using the meta-model concepts (e.g., <<Flow Network>>, <<Flow Edge>>, etc.) to develop a “domain specific language”, with semantics that are easily understood by the domain experts and stakeholders

Transport channel behavior

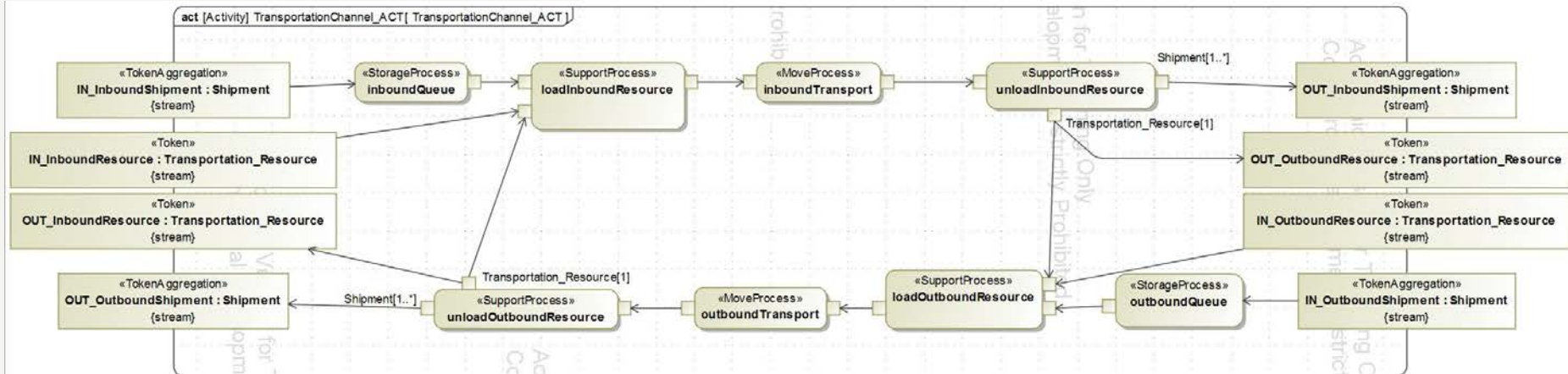

For this to work, we have to be precise—the system instance model cannot be ambiguous, because that will prevent reliable transformation to analysis models.



SC “class” Reference model

- Includes slots for source-sink flow network
- Includes slots for transportation network
- Includes slots for depots, fleets, and vehicle dispatch control

- Create an “instance” of the supply chain “class” which contains all the information you have for a particular supply chain design.
- Or, alternatively, create an data schema and a database with a record for every “instance” of the supply chain “class”; now you have all the information you need to describe a particular supply chain instance.

Hierarchical DESIGN analysis

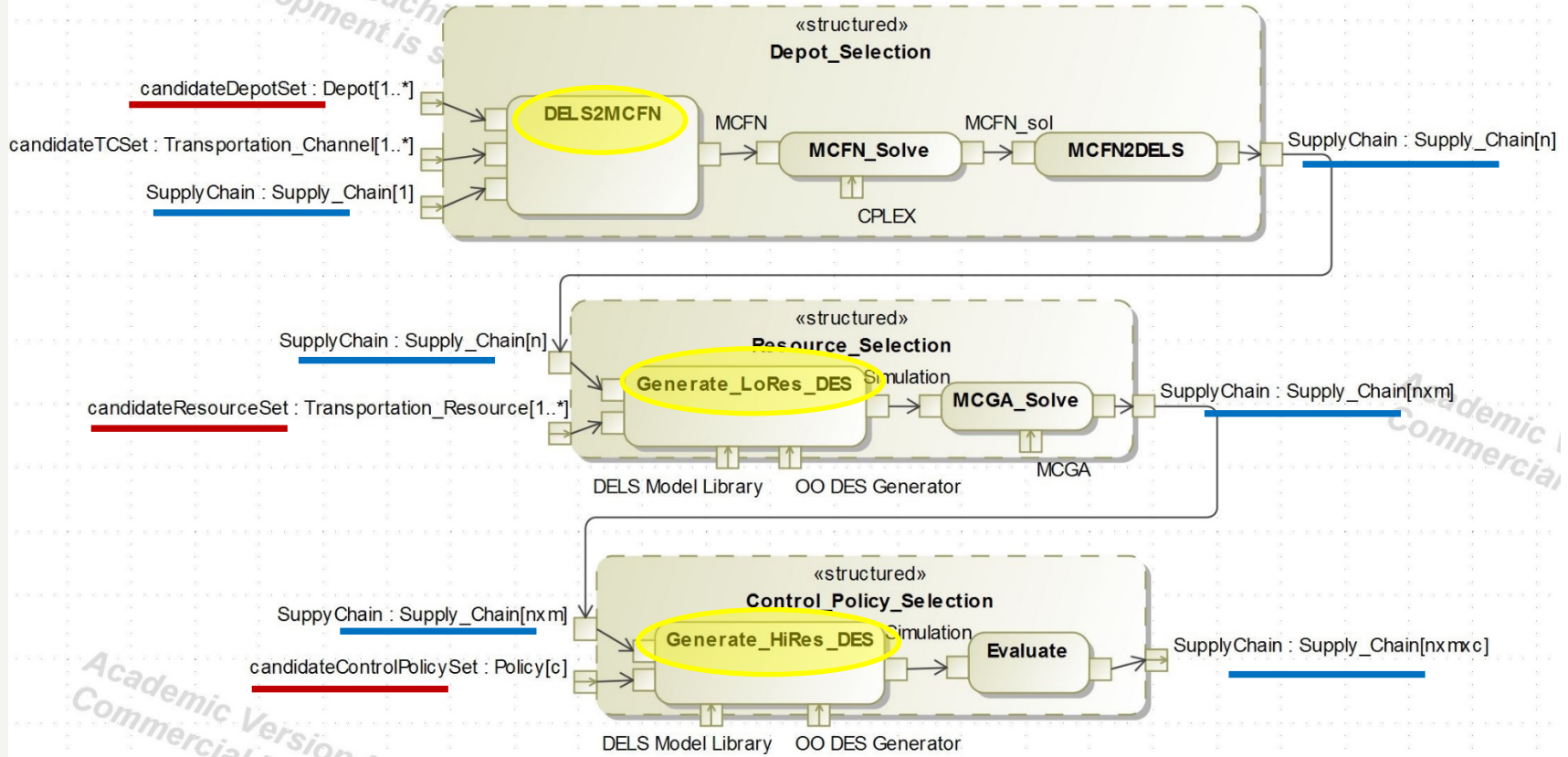

Each analysis “conforms” to the supply chain reference model, thus works for any “instance” of the supply chain object.

Structure: Depot Selection via MCFN

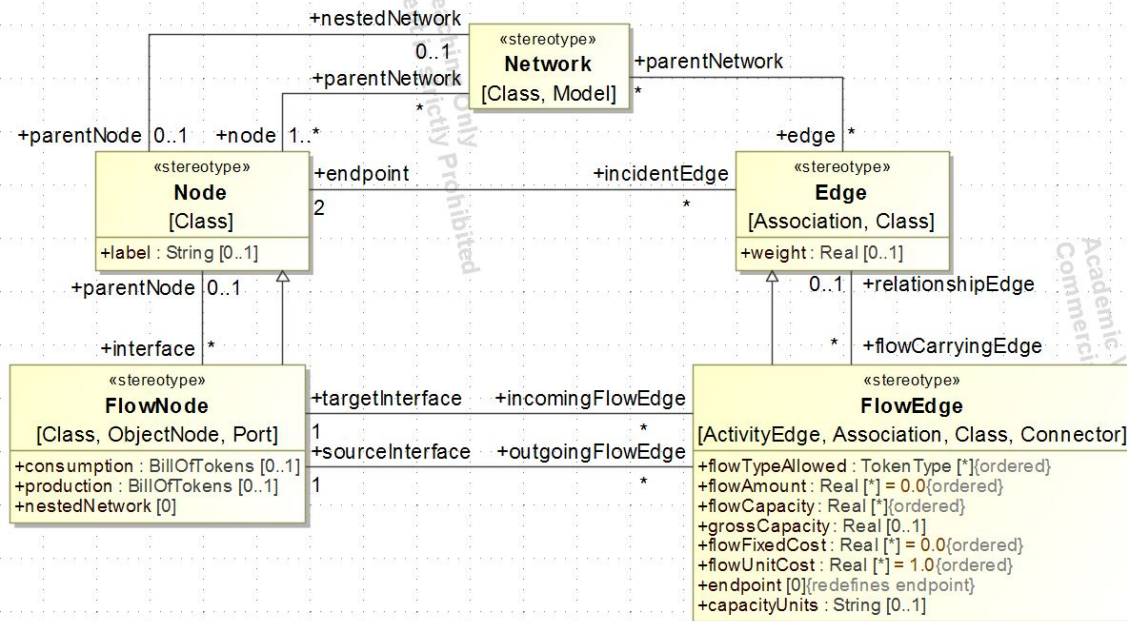

Goal: Reduce the computational requirements of optimizing the distribution network structure.

Strategy: Formulate and solve a corresponding multi-commodity flow network and facility location problem.

- Aggregate and approximate the flows and costs
- Solve MCFN using a COTS solver (CPLEX)
- Apply a “leave one out” strategy to generating several feasible candidate network structures.
- In this case, generate 5 candidates

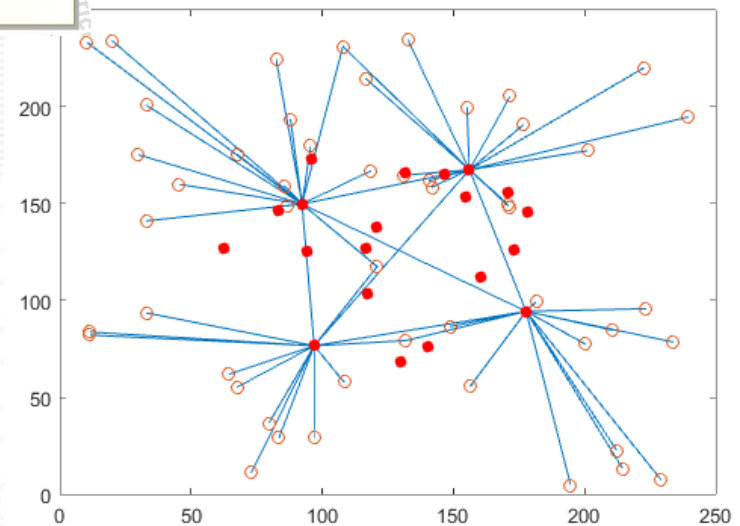

Behavior: Resource Selection

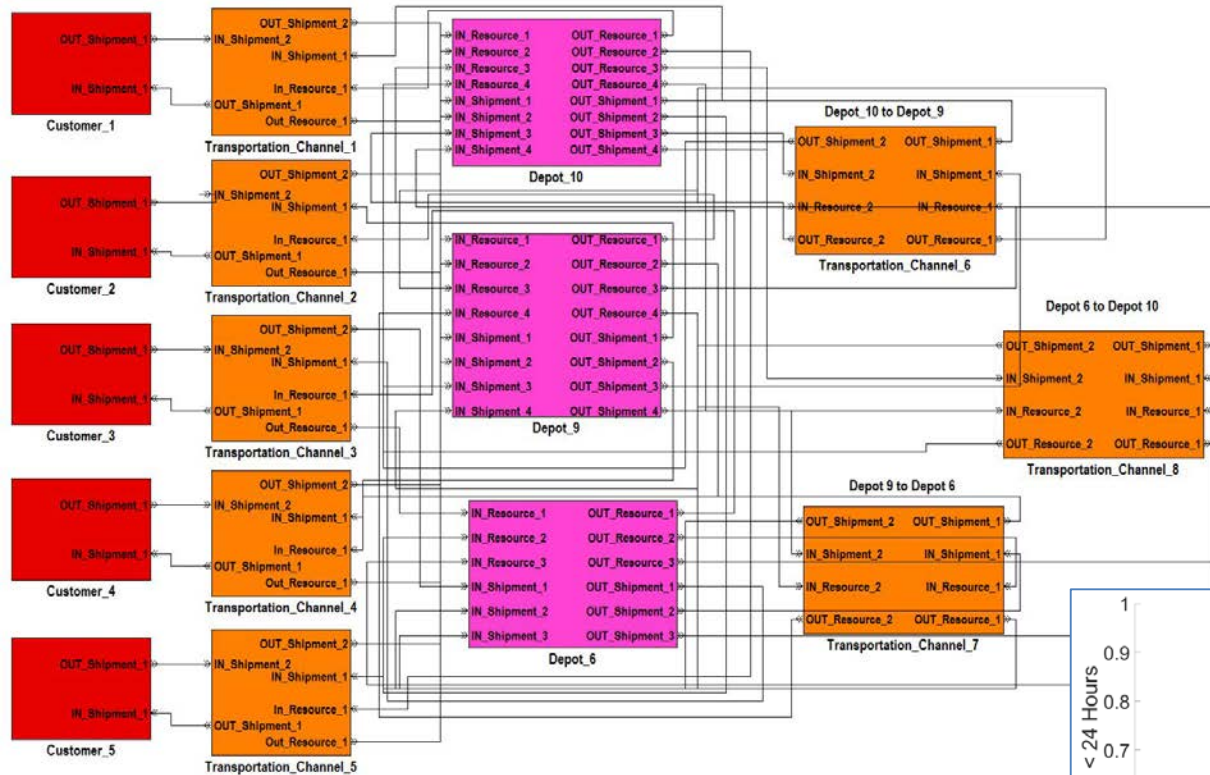

- For each candidate supply chain network structure, generate a portfolio of solutions to the fleet sizing problem
- Trade-off cycle time/service level and resource investment cost

Goal: Capture and evaluate the behavioral aspects of the system using discrete event simulation.

Strategy: Generate a DES that simulates a probabilistic flow of commodities through the system.

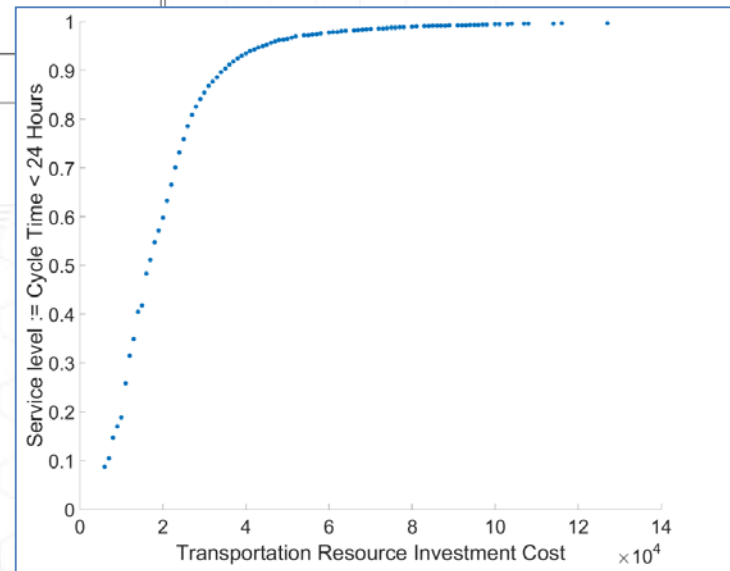

Control: Resource Assignment

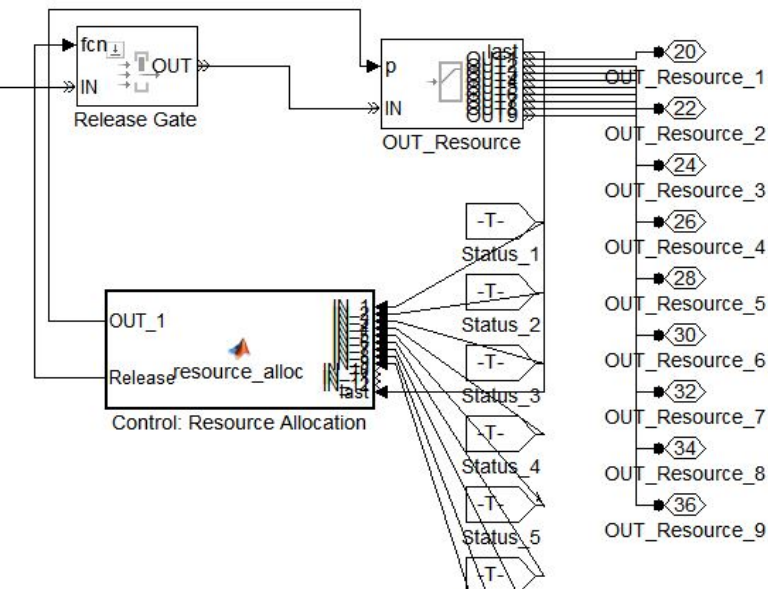

Goal: Select and design a detailed specification of the control policies for assigning trucks to pickup/dropoff tasks at customers.

Strategy: Generate a high-fidelity simulation that is detailed enough to fine-tune resource and control behavior.

Generate a Pareto set of solutions that trade-off Service Level, Capital Costs, and Travel Distance

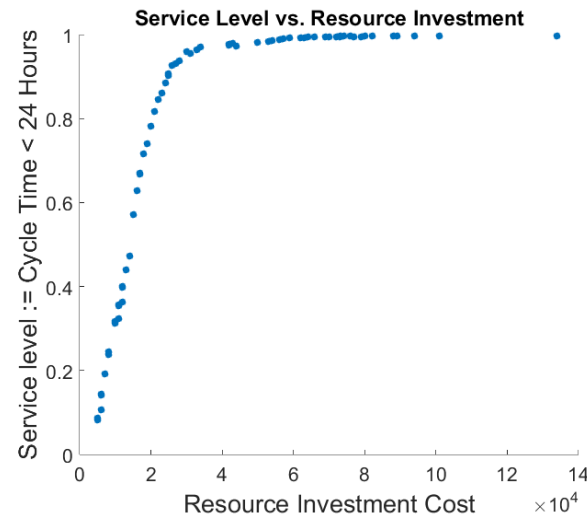
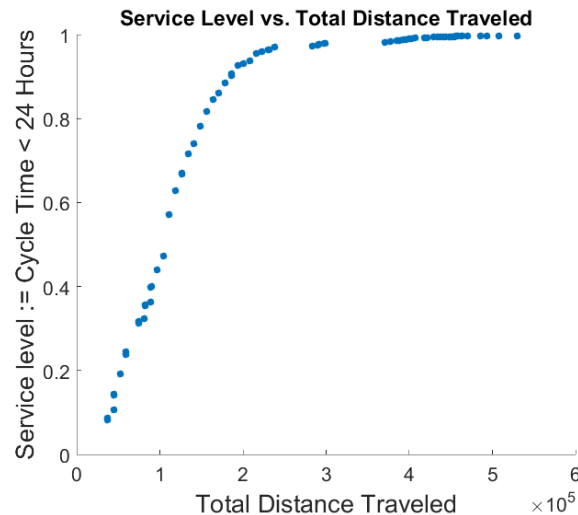
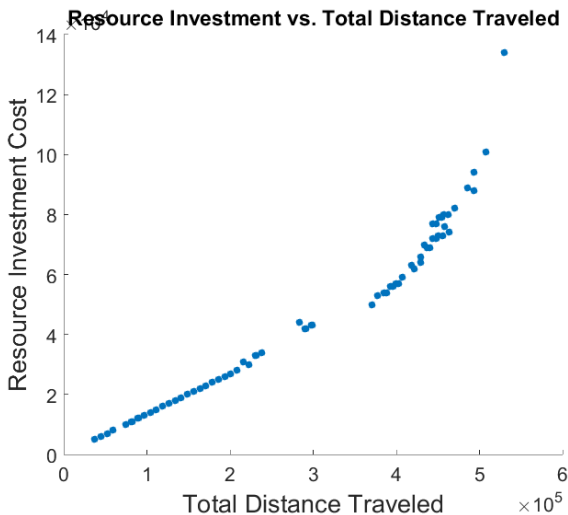

Kinds of results

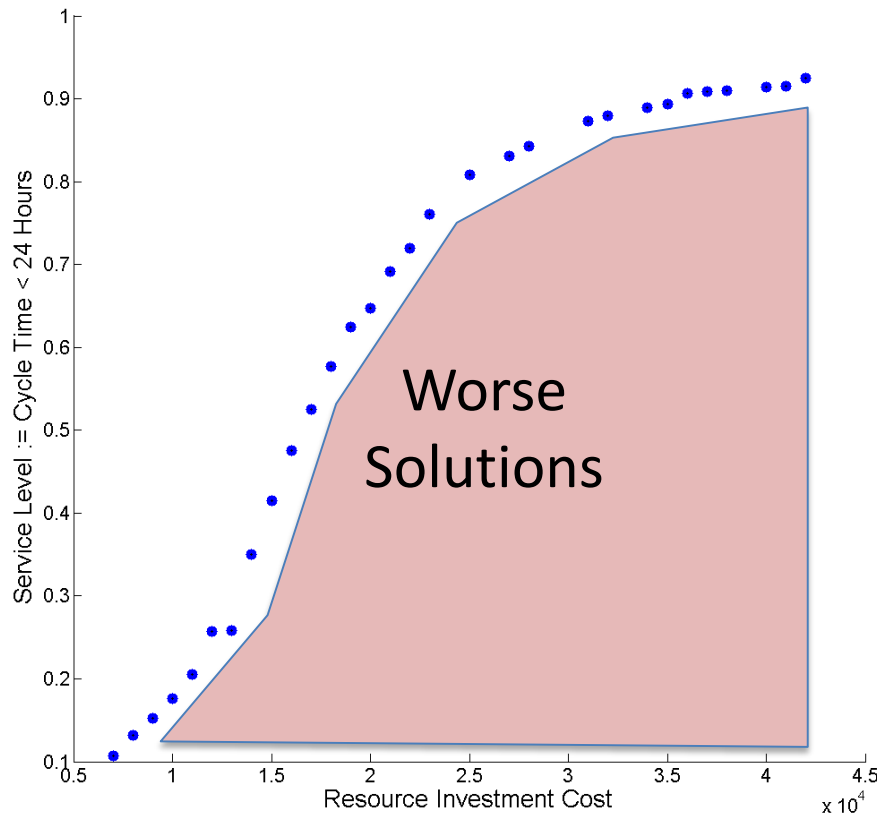

- These are Pareto optimal designs
- Decision makers make trade-offs
- Hundreds, perhaps thousands of simulation runs, with varying depot location decisions, varying fleet configurations, varying control policies—all generated algorithmically

Current Status

- Large demonstration project on high volume central fill pharmacies (Keck VFL)
- Start up company focused on adding decision support to value stream maps (ModGeno)
- Creating a challenge team within INCOSE MBSE Initiative (NIST + Keck VFL + ?)

Are We There Yet?



<http://www.imdb.com/title/tt0368578/mediaviewer/rm3959165184>



