

# An Operational Control Design Methodology for Warehouse Order Fulfillment

**Timothy Sprock**  
Leon F. McGinnis

Stewart School of Industrial and Systems  
Engineering, Georgia Tech, Atlanta, GA



**Georgia** Institute  
of **Tech**nology®

- Engineering Design Methodology
- Semantics: Warehouse Reference Model
  - Operational Control Specification
- Warehouse Design Process
  - Applying the Design Process to Operational Control
- Computational Tool Support
  - Requirement for Simulation and Optimization Tools

- Reference architecture / model or **common semantic framework** for discussing the artifact
- A **design process** or workflow for eliciting requirements from the stakeholder(s) and translating them into a complete specification
- **Computational tools** based on the reference model to support the design process

- Three components of the design methodology
  - What control decisions must be made?
    - A canonical description of operational control
  - Where do control decisions need to be made?
    - A design methodology leads to a specification of all the control decisions that need a control behavior specified.
  - How do we specify the control behavior?
    - Decision support and analytical support for both the design process and the control execution (what tools are required?)
    - Provide a pathway from design and analysis of controllers to prototyping and testing to deployment

- Engineering Design Methodology
- **Semantics: Warehouse Reference Model**
  - Operational Control Specification
- Warehouse Design Process
  - Applying the Design Process to Operational Control
- Computational Tool Support
  - Requirement for Simulation and Optimization Tools

# WAREHOUSE REFERENCE MODEL

DELS are characterized by a **product** moving through a network of **resources** (configured within a **facility**), where **processes** transform the product in some way. A warehouse can be thought of as two DELS working in tandem.

In the warehousing context, the **product**, or order, families can be defined by the additional processes that they must go through, e.g. kitting, labeling, or other customization. The warehouse reference model should define broad classes of **processes**, e.g. picking methods or process, and the associated required **resources**.

Provides a bridge to analysis models and the basis for reusable infrastructure for generating analysis models

Interoperability between the system definition and libraries of plug-and-play analysis models and their corresponding tools

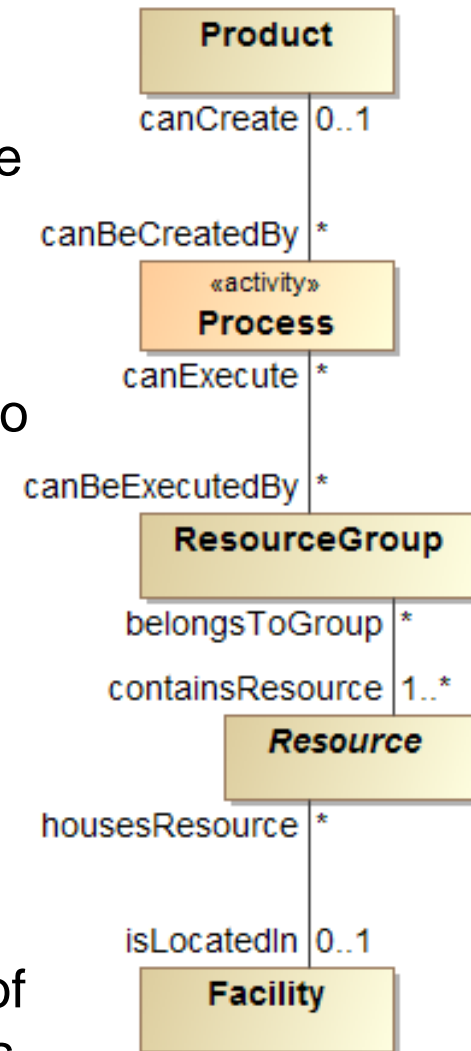

- Engineering Design Methodology
- Semantics: Warehouse Reference Model
  - **Operational Control Specification**
- Warehouse Design Process
  - Applying the Design Process to Operational Control
- Computational Tool Support
  - Requirement for Simulation and Optimization Tools

Control questions provide a mapping from a formal functional definition of control activities for DELS to formal (math programming) analysis models.

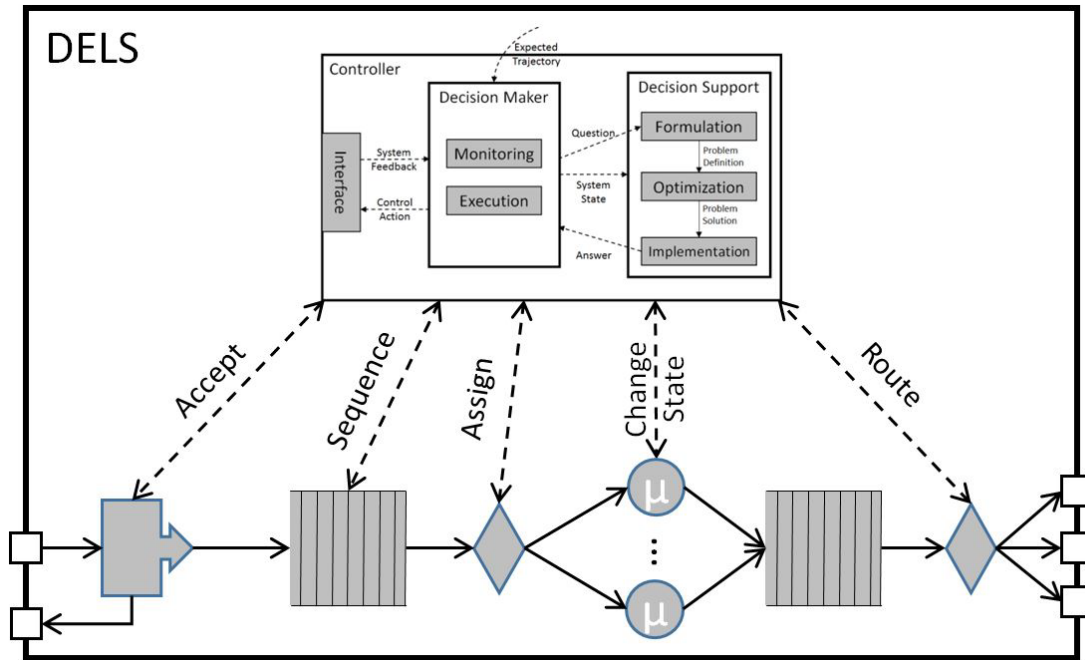

- Which tasks get serviced? (Admission/Induction)
- When {sequence, time} does a task get serviced? (Sequencing/Scheduling)
- Which resource services a task? (Assignment/Scheduling)
- Where does a task go after service? (Routing)
- What is the state of a resource? (task/services can it service/provide)



In the warehousing context, **the canonical questions have the following interpretation:**

- 1. Admission control** may evaluate available resource capacity, both inventory on hand and fulfillment capacity, to decide whether or not to release an order;
- 2. Sequencing** customer orders include decisions such as coordination (of orders outbound on the same truck), batching (wave planning and batching), delaying (backordering orders), and splitting (splitting a complete order to be picked from different zones);
- 3.** Many interrelated **resource allocation** problems including assigning labor and material handling equipment to load and unload the carrier trucks and pick and put-away products into storage. However, there are also auxiliary resources such as docks, sorter lanes, and storage locations that need to be assigned to trucks, orders, and SKUs to be stored, respectively;
- 4. Routing**, or process planning, includes building routes for pickers and optimal routing for AMHS, as well as routing orders through the facility to the different processes required or when additional processing is required such in the case of exceptions or quality inspection; and
- 5. Changing the capability or capacity** of resources includes replenishment of stocked inventory, maintenance on automated systems to maintain capacity, or anticipatory moves and pre-positioning of inventory or AMHS pickers/vehicles.

- The control questions are captured in the reference model as a design pattern
  - Maps the **decision variables** in the controller's decision problem to a particular controller **behavior** and to an **execution mechanism** in the plant
- Classes of control behaviors
  - Complex static priority rules
  - Ranking and selection methods for control rules
  - Dynamic rule selection methods
    - Decision trees or production rule systems
  - Artificial Neural Networks
  - On-line optimization approaches

- A controller must decide if it wants to service a particular task when it becomes available to the system
  - Creates the ability to control the rate of arrivals by allowing or rejecting tasks
- Formulation
  - $\widehat{\mathcal{L}}_t$  is the set of tasks that first become available in period  $t$
  - The admission problem is to select  $L_t^* \subseteq \widehat{\mathcal{L}}_t$
  - Admission variable:  $y_i = 1$  if  $l_i \in \widehat{\mathcal{L}}_t$  is accepted or not
  - Capacity control variable:  $u_i(t)$  is the probability of accepting a request for product  $i$  at time  $t$
  - Price schedule mechanism:  $\{(p_k, \tau_k)\}$  for  $k=0$  to  $K$ ; where  $K$  is the number of market segmentations and  $p_k$  is the offered price if a customer agrees to lead time  $\tau_k$ . Then  $\lambda(p, \tau)$  is the expected aggregate demand.

# EXAMPLE: ADMISSION CONTROL

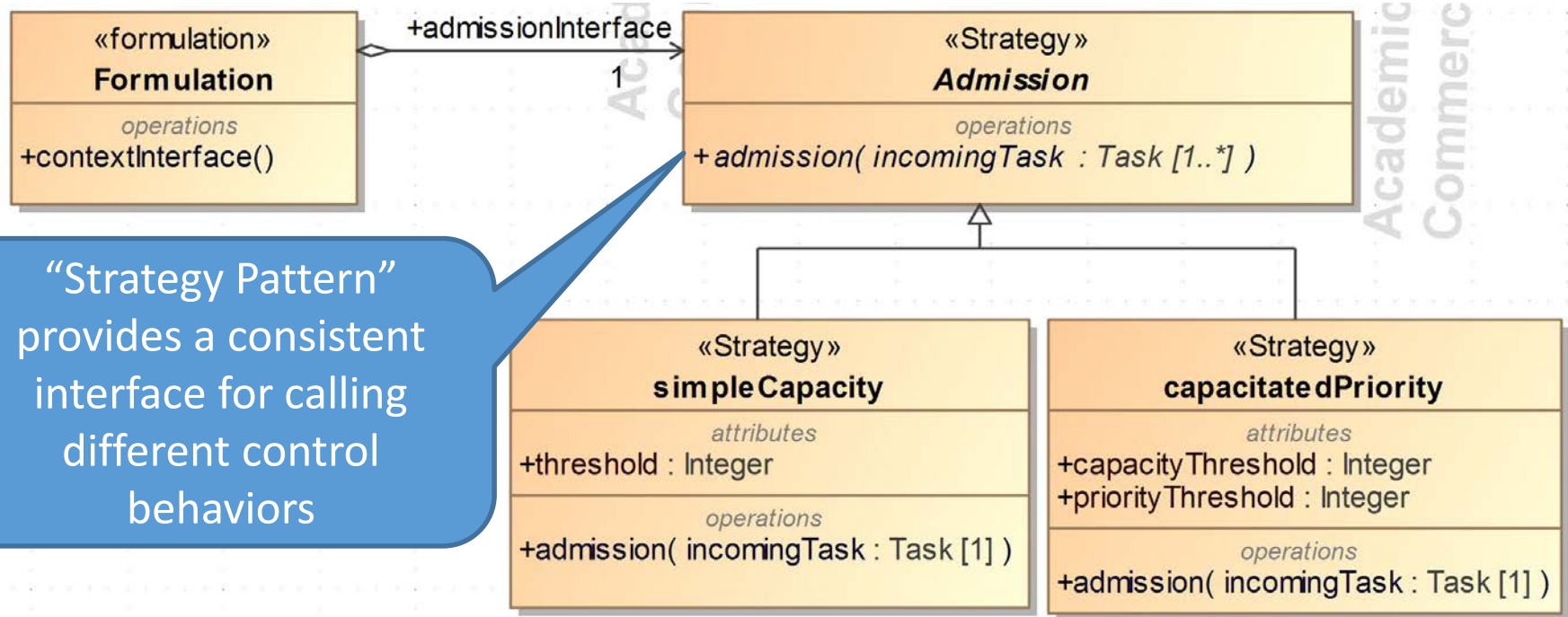

- For each control question, there may be several analysis methods available to provide an answer, each with different solution quality and run time performance guarantees.
- If the controller is going to provide real-time decision-making, it needs to be configured with dynamic control policies

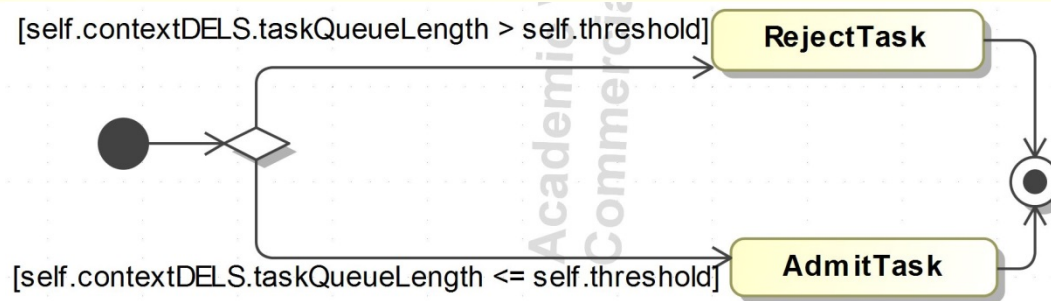

Need a specification of the function required to execute the *AdmitTask()* behavior

$$\text{admitTask}(\text{task}) =_{Def} \text{System.TaskSet} \cup \{\text{task}\}$$

This can be implemented as:

- A call-behavior to an admission gate
- Giving the arriving task an authorization token

In practice it's likely that the admission gate is implemented with a more concrete "actuator" component that implements the required behavior; e.g. to implement the *admitTask()* behavior, a robotic arm is tasked to retrieve an arriving task from the AMHS conveyor and place it into a physical storage slot.<sup>13</sup>

# SIMEVENTS EXAMPLE: ADMISSION

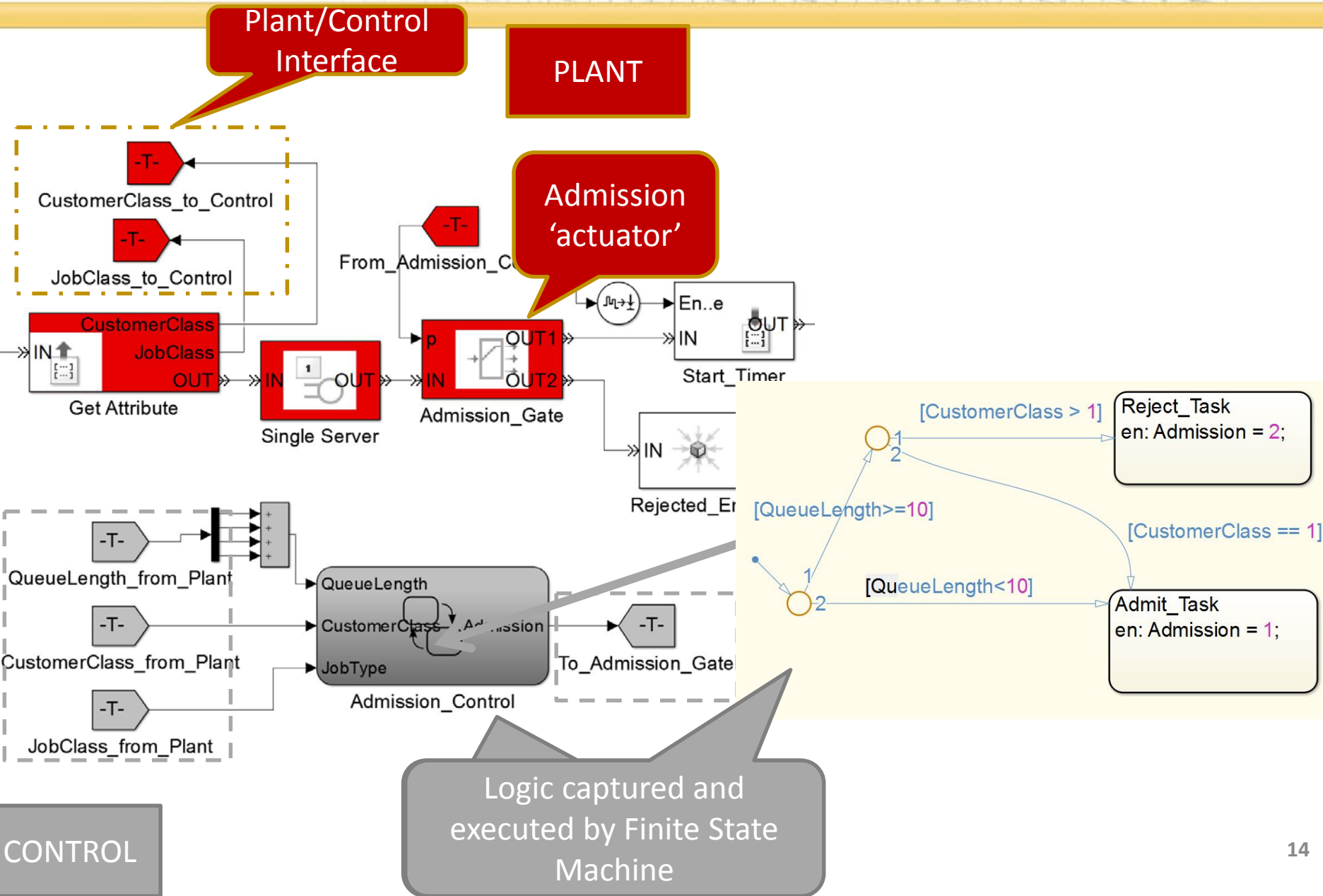

- Engineering Design Methodology
- Semantics: Warehouse Reference Model
  - Operational Control Specification
- **Warehouse Design Process**
  - Applying the Design Process to Operational Control
- Computational Tool Support
  - Requirement for Simulation and Optimization Tools

- Functional Requirements Analysis
  - Characterize the INFlows and OUTFlows
    - SKU Families and Order Families
- Functional Design
  - What must be done to transform INFlows into OUTFlows
- Embodiment Design
  - Select and configure resources, processes, and facility layout
  - **Identify and design control rules and behaviors**



- Engineering Design Methodology
- Semantics: Warehouse Reference Model
  - Operational Control Specification
- Warehouse Design Process
  - **Applying the Design Process to Operational Control**
- Computational Tool Support
  - Requirement for Simulation and Optimization Tools

# HOW TO USE THESE PRINCIPLES

Identify required control behaviors and provide a design and optimization methodology for specifying those behaviors

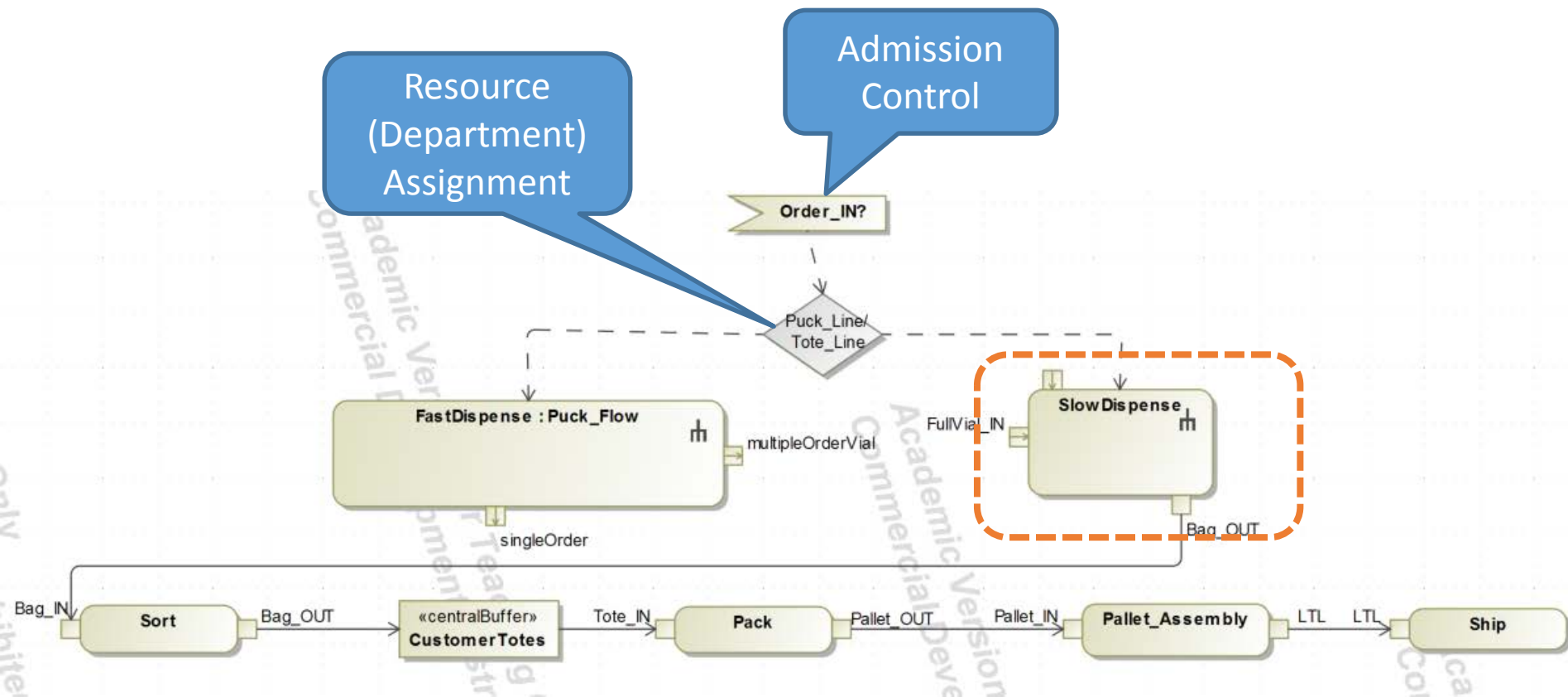

# SLOWDISPENSE (FULL)

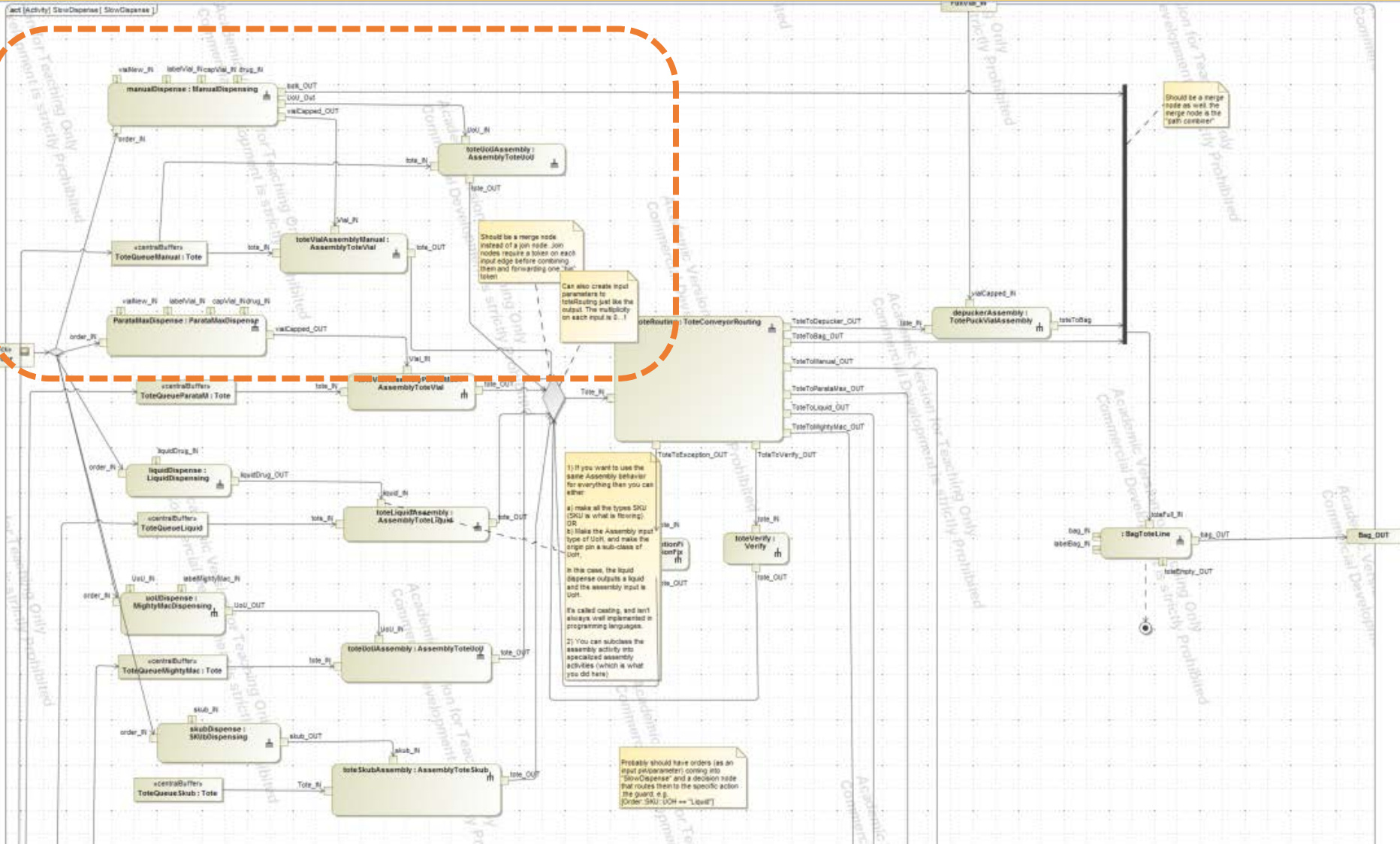

Resource Assignment (based on capability)

Routing (where does it go next?)

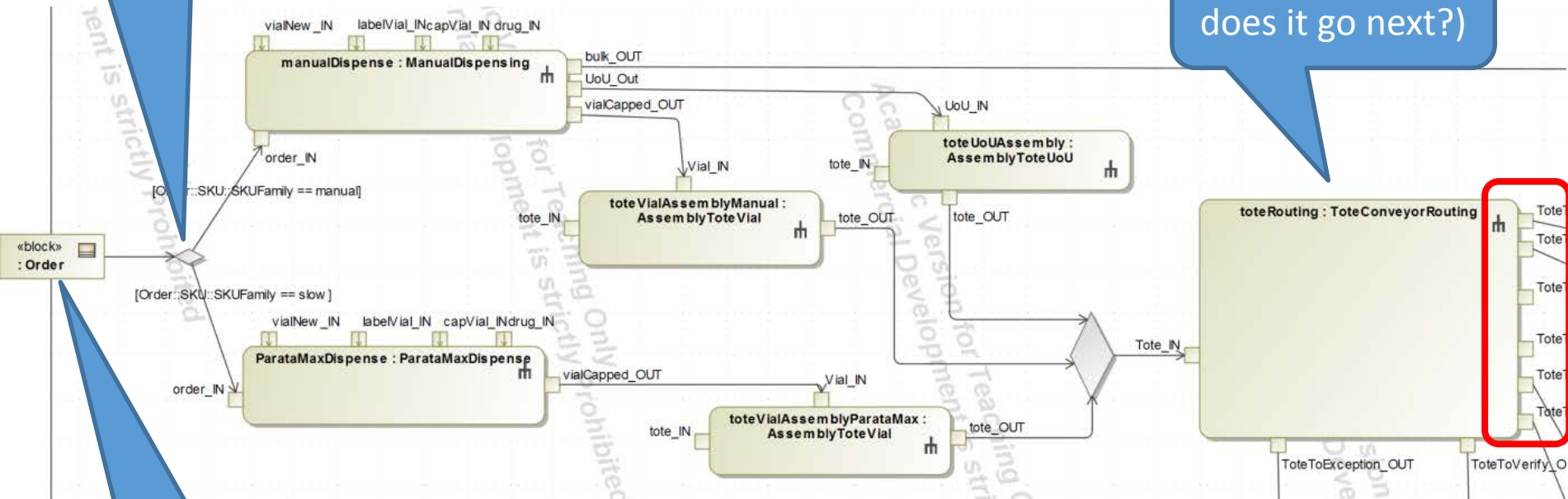

Sequencing (or dispatch) behavior

Behavior captured as a state machine

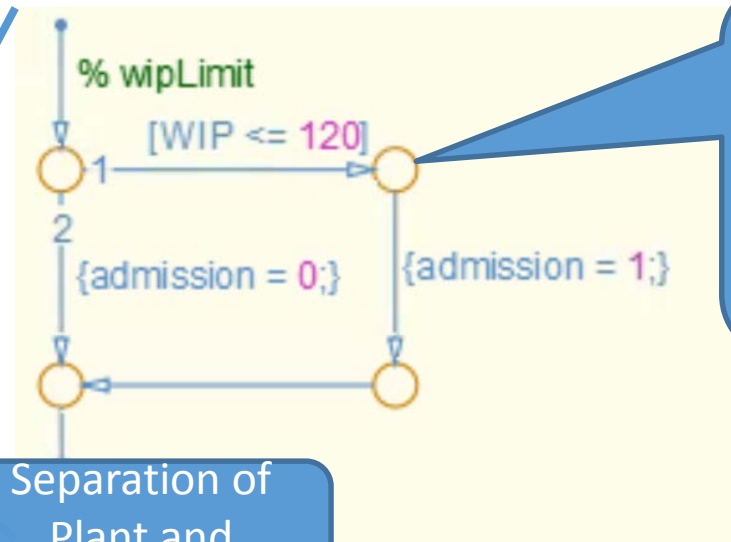
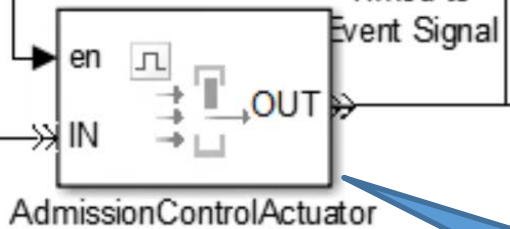
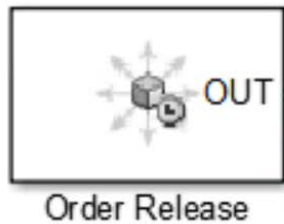
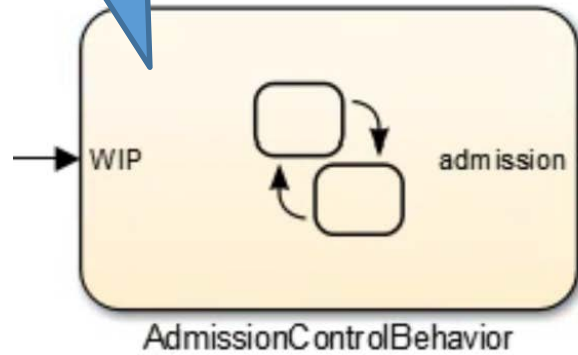

Could be elaborated with sophisticated capacity analysis

Separation of Plant and control

Actuator Mechanism

# ROUTING CONTROL

Behavior captured as a state machine

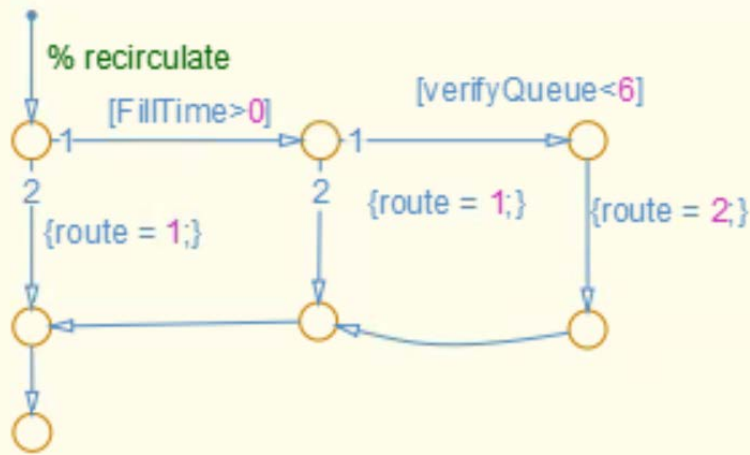

Separation of Plant and control

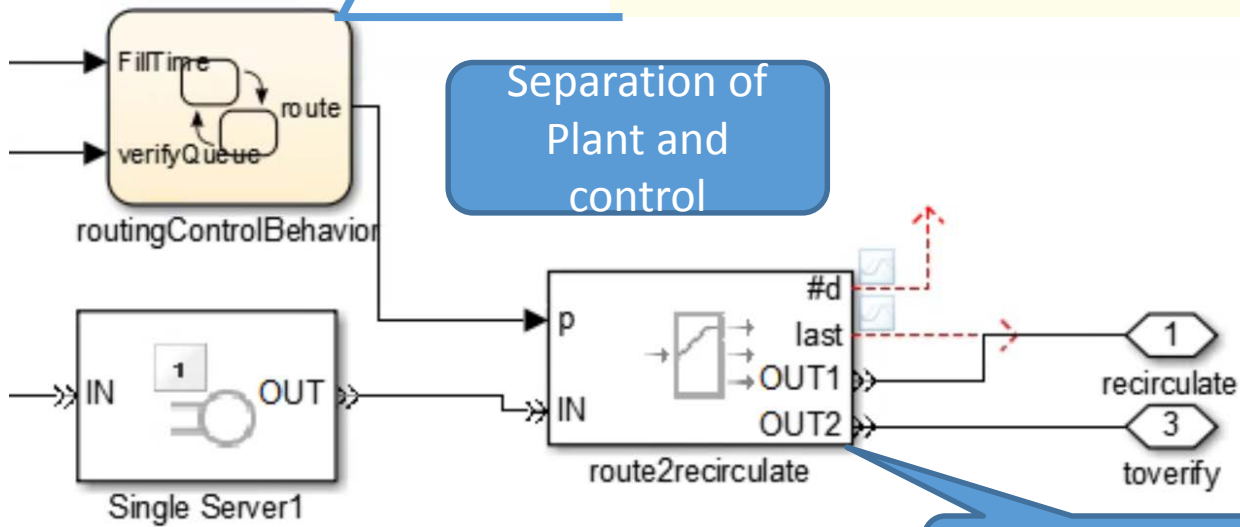

Actuator Mechanism

- Engineering Design Methodology
- Semantics: Warehouse Reference Model
  - Operational Control Specification
- Warehouse Design Process
  - Applying the Design Process to Operational Control
- **Computational Tool Support**
  - Requirement for Simulation and Optimization Tools

Support for two types of decision making:

1. Off-line Design of Operational Control Behavior
  1. Selecting, sequencing, and optimization rules
  2. Design and configuring decision trees or production rule systems (common in manufacturing environments)
  3. Tuning optimization methods and parameters
2. On-line Optimization of Control Decisions
  1. Real-Time Scheduling, etc.



What is the role of the reference architecture and design methodology?

- Organize the literature on control optimization around the extensions to the product, process, resource, and facility description of the system
- What tools are available and required to support each stage and each decomposition of the design process?
- Is there a canonical decomposition of the decision space?

- Modeling Control in Simulation
  - Separation of Plant and Control
  - Implementation of Control Methods and Tools
  - Natural mapping between system modeling languages and analysis/simulation modeling languages
- Implementations of the Controller
  - Interaction with a simulation “base system”
  - Sandbox to experiment with control methods and tools
  - Provide a pathway from design and analysis of controllers to prototyping and testing to deployment

- Three components of the design methodology
  - What control decisions must be made?
    - A canonical description of operational control
  - Where do control decisions need to be made?
    - A design methodology leads to a specification of all the control decisions that need a control behavior specified?
  - How do we specify the control behavior?
    - Decision support and analytical support for both the design process and the control execution (what tools are required?)
  - Provide a pathway from design and analysis of controllers to prototyping and testing to deployment

# Questions & Comments

[leon.mcginnis@isye.gatech.edu](mailto:leon.mcginnis@isye.gatech.edu)

[tsprock3@gatech.edu](mailto:tsprock3@gatech.edu)